

LM108 Series—Precision Operational Amplifier

INTRODUCTION

The LM108/108A series are precision operational amplifiers having specifications a factor of ten better than FET amplifiers over their operating temperature range. In addition to low input currents, these devices have extremely low offset voltage, making it possible in most cases, to eliminate offset adjustments.

FEATURES	LM108	LM308	LM108A/ 308A
Maximum input bias current	3.0nA over temp.	7.0nA	3.0nA over temp.
Offset current	Less than 400pA over temp.	Less than 1.0nA	Less than 400pA over temp.
Supply current (even i in saturation)	300μA	300μA	300μA
Guaranteed drift characteristics			5μV/°C
Offset voltage guaranteed low current error			Less than 0.5mV

MAXIMUM RATINGS

PARAMETER	RATING		UNIT
	LM108A/ 108	LM308A/ 308	
Supply voltage	±20	±18	V
Power dissipation ^{1,4}	500	500	mW
Differential input current ²	±10	±10	mA
Input voltage ³	±15	±15	V
Output short-circuit duration	Continuous	Continuous	
Operating temperature range			
LM108, LH2108	-55 to +125	0 to +70	°C
Storage temperature range	-65 to +150	-65 to +150	°C
Lead temperature (soldering 10 sec)	+300	+300	°C

NOTES

- The maximum junction temperature of the LM108/108A is 150°C, while that of the LM208/208A is 100°C. For operating at elevated temperatures, devices in the TO-5 package must be derated based on a thermal resistance of 150°C/W, junction to ambient, or 45°C/W, junction to case. The thermal resistance of the dual-in-line package is 100°C/W, junction to ambient.
- The inputs are shunted with back-to-back diodes for overvoltage protection. Therefore, excessive current will flow if a differential input voltage in excess of 1V is applied between the inputs unless some limiting resistance is used.
- For supply voltages less than ±15V, the absolute maximum input voltage is equal to the supply voltage.
- The maximum junction temperature of the LM308 is 85°C. For operation at elevated temperatures, devices in the TO-5 package must be derated based on a thermal resistance of 150°C/W, junction to ambient, or 45°C/W, junction to case. The thermal resistance of the dual-in-line package is 100°C/W, junction to ambient.

CONNECTION DIAGRAM

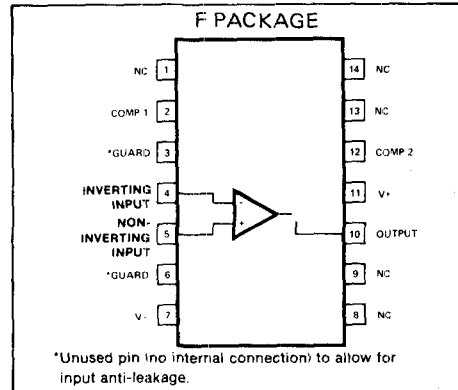
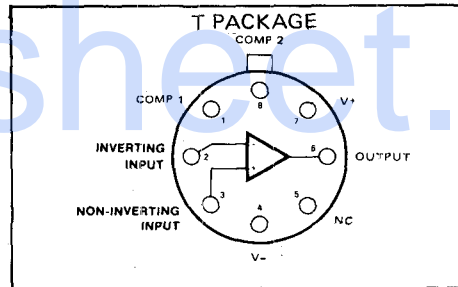
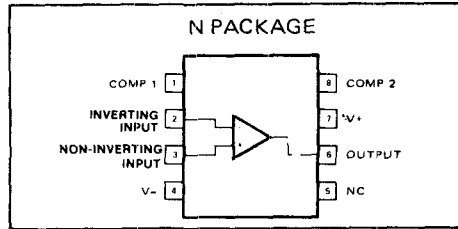

REFERENCE TABLE

TYPE NO.	STOCK NO.	OUTLINE DRWG. NO.
LM108F	55902C	1
LM108AF	55903A	1
LM108T	55904X	7
LM108AT	55905H	7
LM308N	55906F	8
LM308N-14	55907D	1
LM308AN	55908B	8
LM308AN-14	55909X	1
LM308T	55910C	7
LM308AT	55911A	7

PLEASE QUOTE STOCK NO.
AND MANUFACTURERS PART NO. WHEN ORDERING



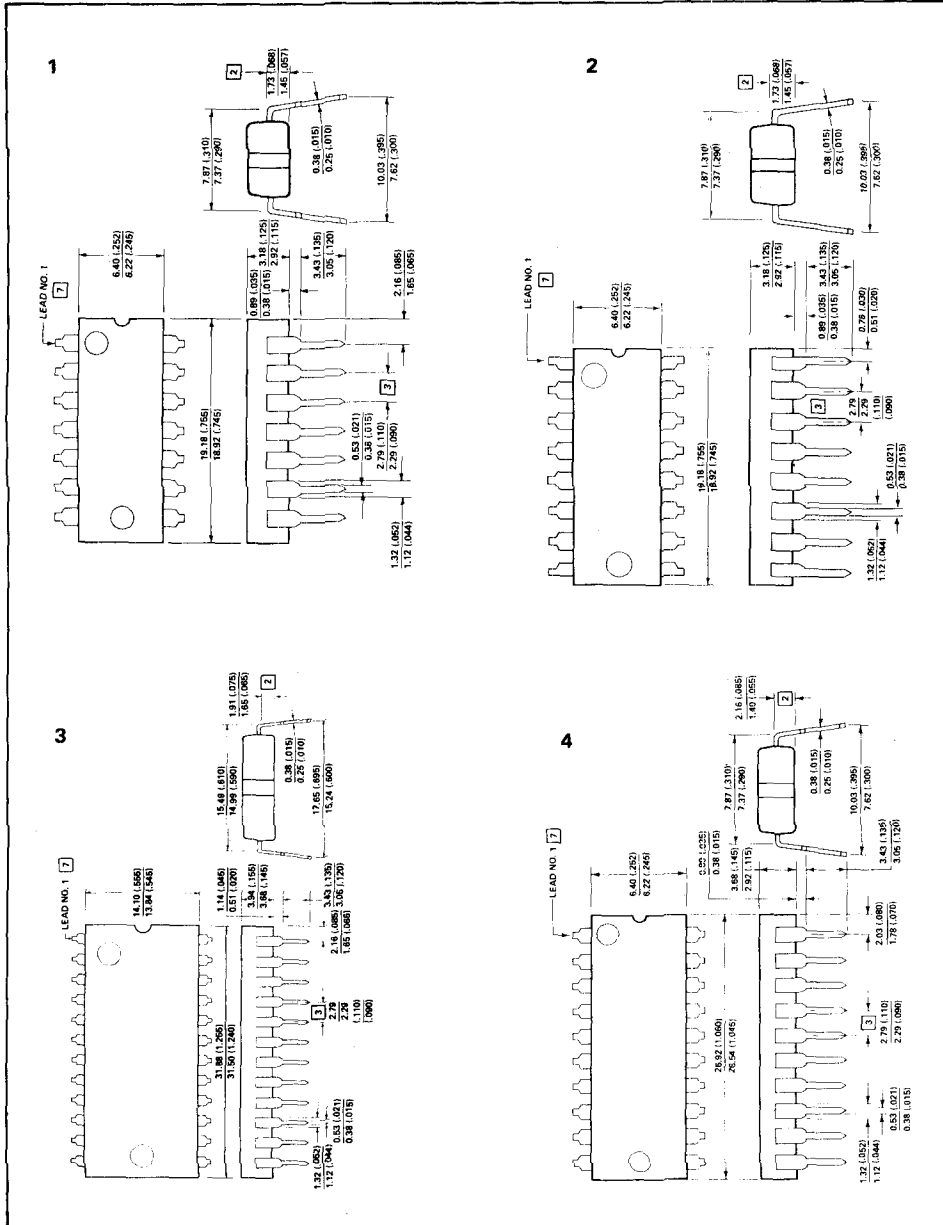

PLEASE QUOTE STOCK NO.
AND MANUFACTURERS PART NO. WHEN ORDERING



Signetics

Outline Drawings

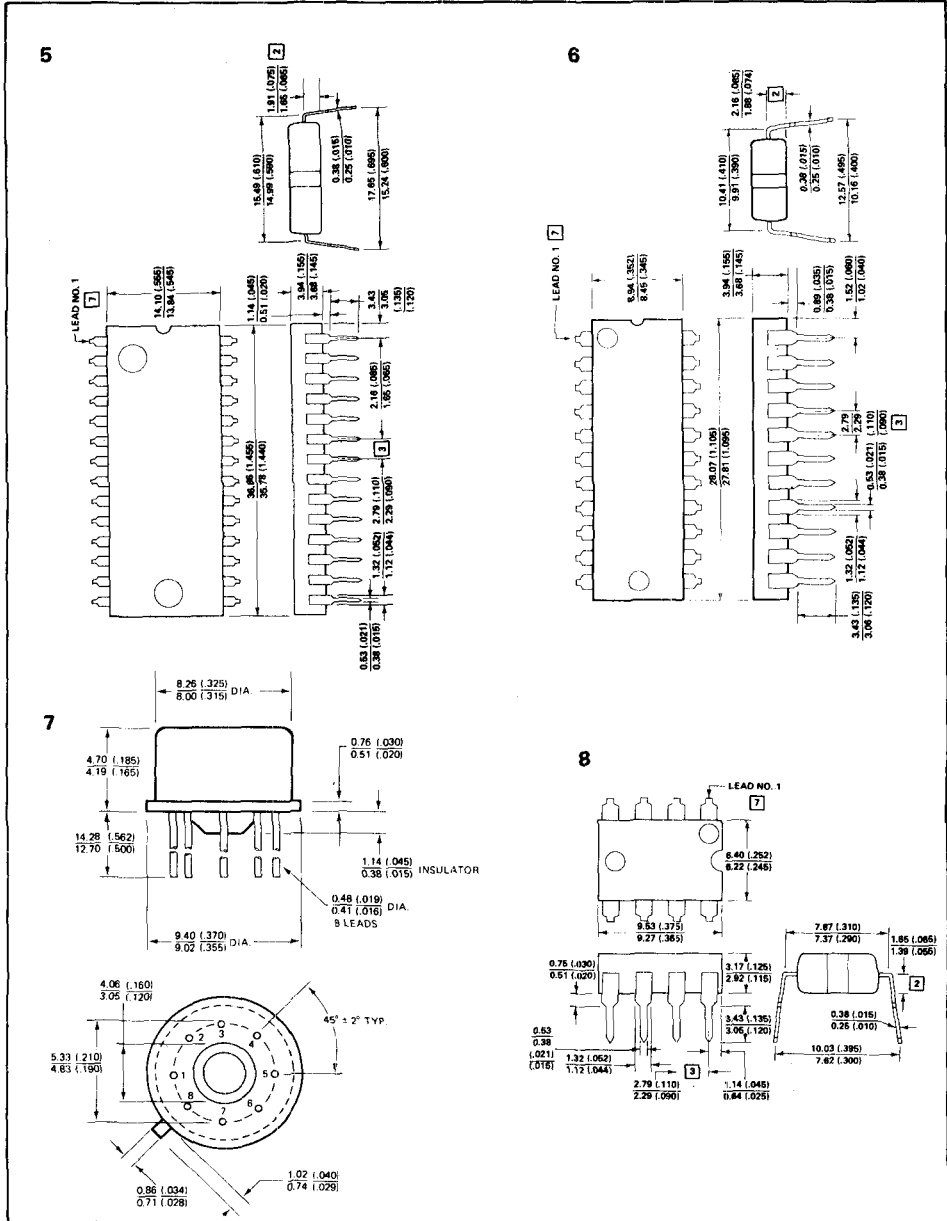

GEMINI

FOR CURRENT PRICES PHONE
HARLOW (0279) 29644

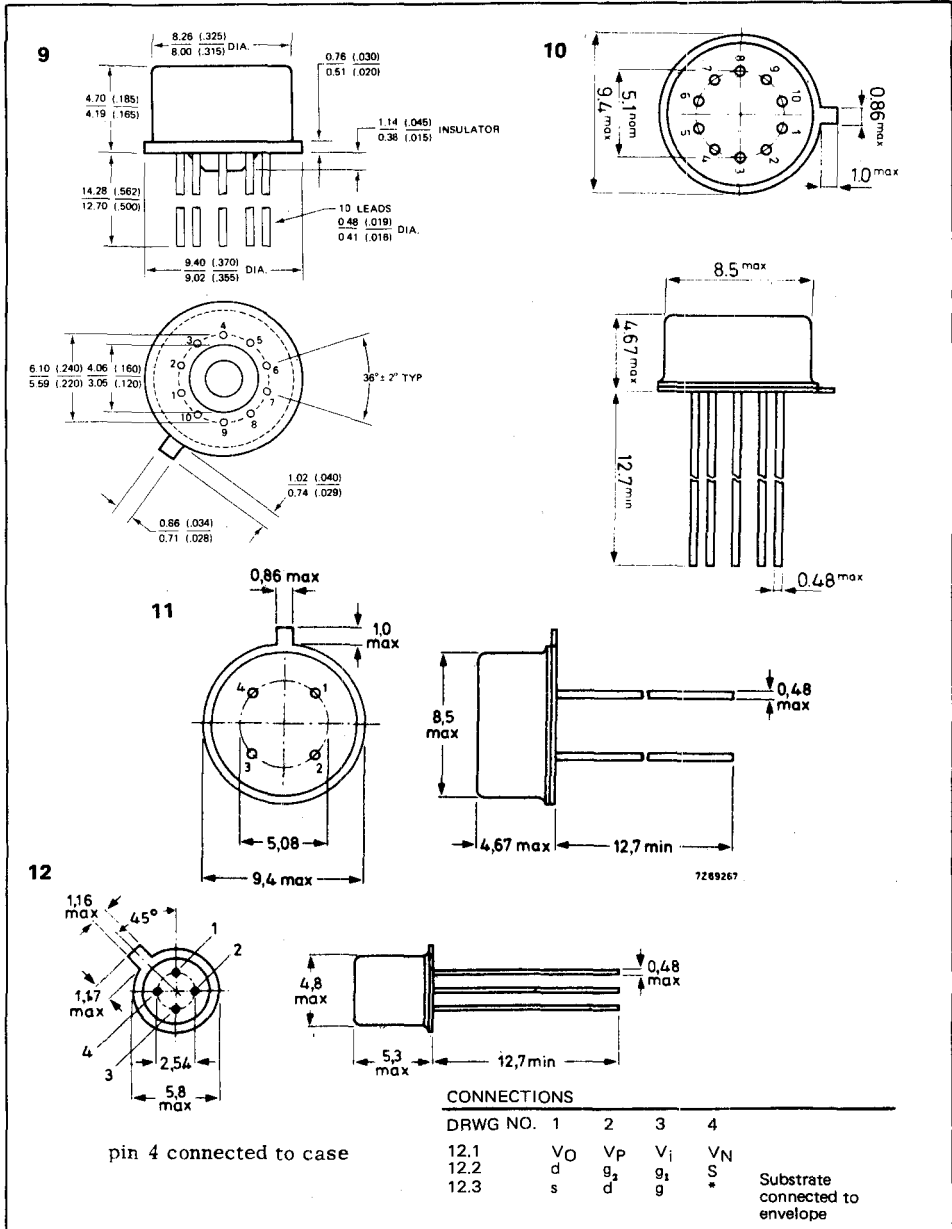

PLEASE QUOTE STOCK NO.
AND MANUFACTURERS PART NO. WHEN ORDERING

ITT GEMINI

Signetics

Outline Drawings

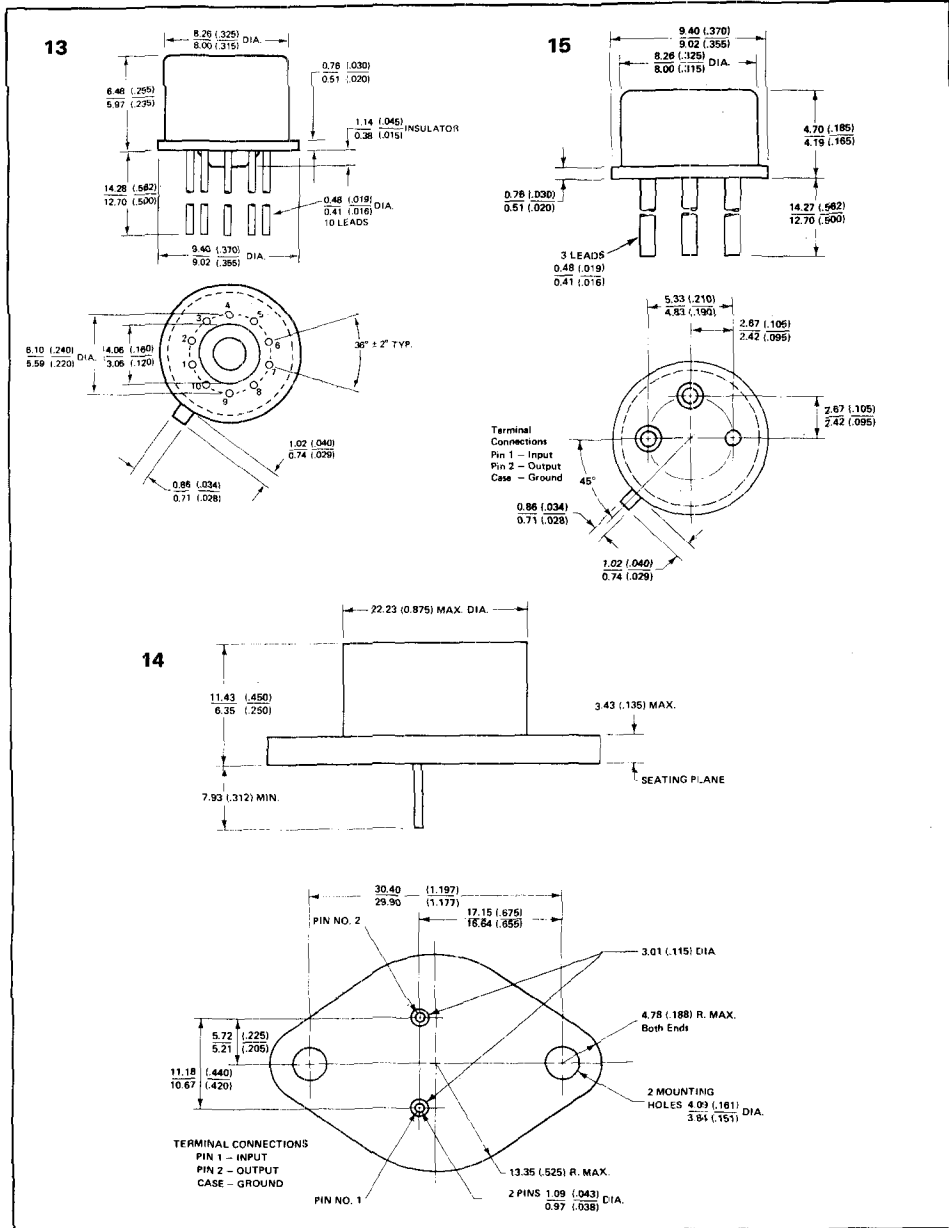

ITT GEMINI

FOR CURRENT PRICES PHONE
HARLOW (0279) 29644

16

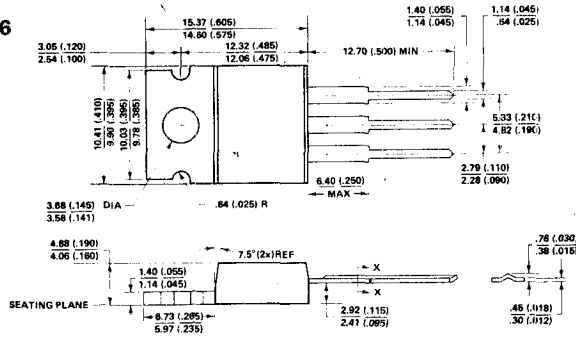

17

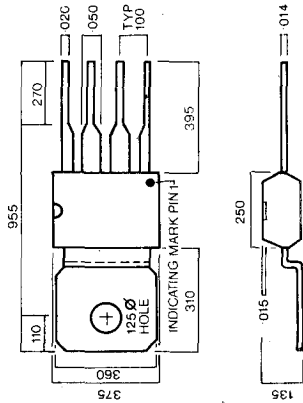

19

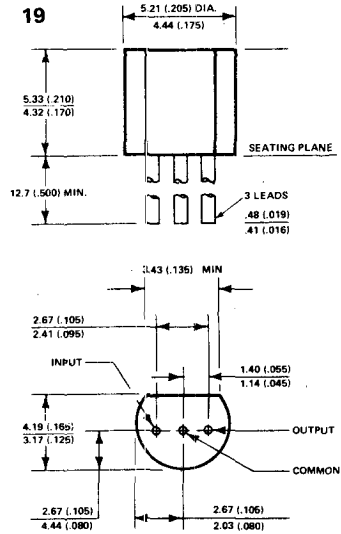

PLEASE QUOTE STOCK NO.
AND MANUFACTURER PART NO. WHEN ORDERING

TTT GEMINI

